

SCHS Sample Conditioning Heated System



The Welker SCHS Sample Conditioning Heated System properly conditions a flowing gas stream and protects analyzers from free liquids.

Features

- 3-stage protection system for analyzers
- Pipeline-mounted system for analyzer grade conditioned gas
- Liquid-eliminating probe assembly with integrated liquid and sediment filtration
- Effective sample heat retention before point of regulation to mitigate the Joule-Thomson effect and prevent gas composition from being compromised
- Fail-safe shutoff in the presence of liquid in the system
- Modular design and removable insulated enclosure

Benefits

- Analyzer is fortified by patented lines of protection
- Properly conditioned gas sample for analysis
- Effective protection against costly damage to analyzer
- Compact footprint
- Easy access to individual components for convenient maintenance



R: P₂ Electrical Connection Option Shown

Product and/or components are manufactured under US Patent:
6,764,536 and 7,471,882

SPECIFICATIONS

SCHS SAMPLE CONDITIONING HEATED SYSTEM

SCHS

Materials of Construction	304 Stainless Steel, 316/316L Stainless Steel, Aluminum, Glass, Teflon®, Viton®
Seat Material	Teflon®
Seal Material	Viton®
Pipeline Connection	¾" MNPT
Outlet Connection	⅛" MNPT Tube Connection
Output Range Options	0-25 psig
	0-50 psig
	20-100 psig
Insertion Length	8"
Electrical Connection	AC 120 V
Operating Pressure	2160 psig MAOP @ -20 °F to 100 °F
Industry Standards	Complies With API 14.1 and GPA 2166

STANDARD OPTIONS

SCHS SAMPLE CONDITIONING HEATED SYSTEM

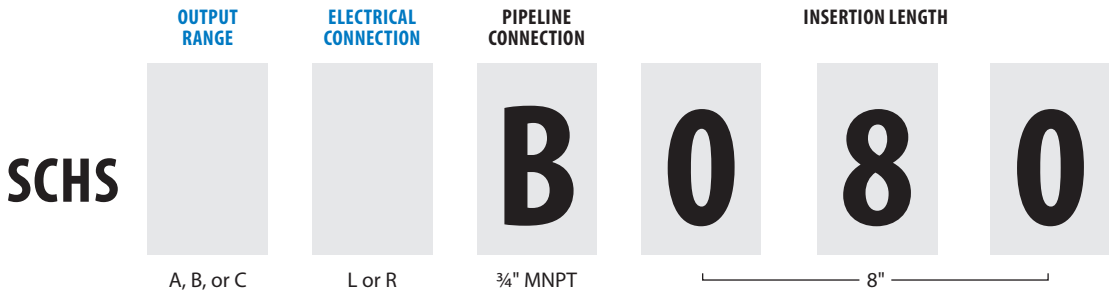

OUTPUT RANGE

- A:** 0-25 psig With 30 psig Gauge, 30 psig Relief
- B:** 20-100 psig With 160 psig Gauge, 130 psig Relief
- C:** 0-50 psig With 60 psig Gauge, 50 psig Relief

ELECTRICAL CONNECTION

- L:** On P₁ Side of Enclosure
- R:** On P₂ Side of Enclosure

For custom options, choose **Plus Welker™**.



Customer Inspired. Welker Manufactured.
Collaborate with us to create a custom product unique to your application.

DIMENSIONS

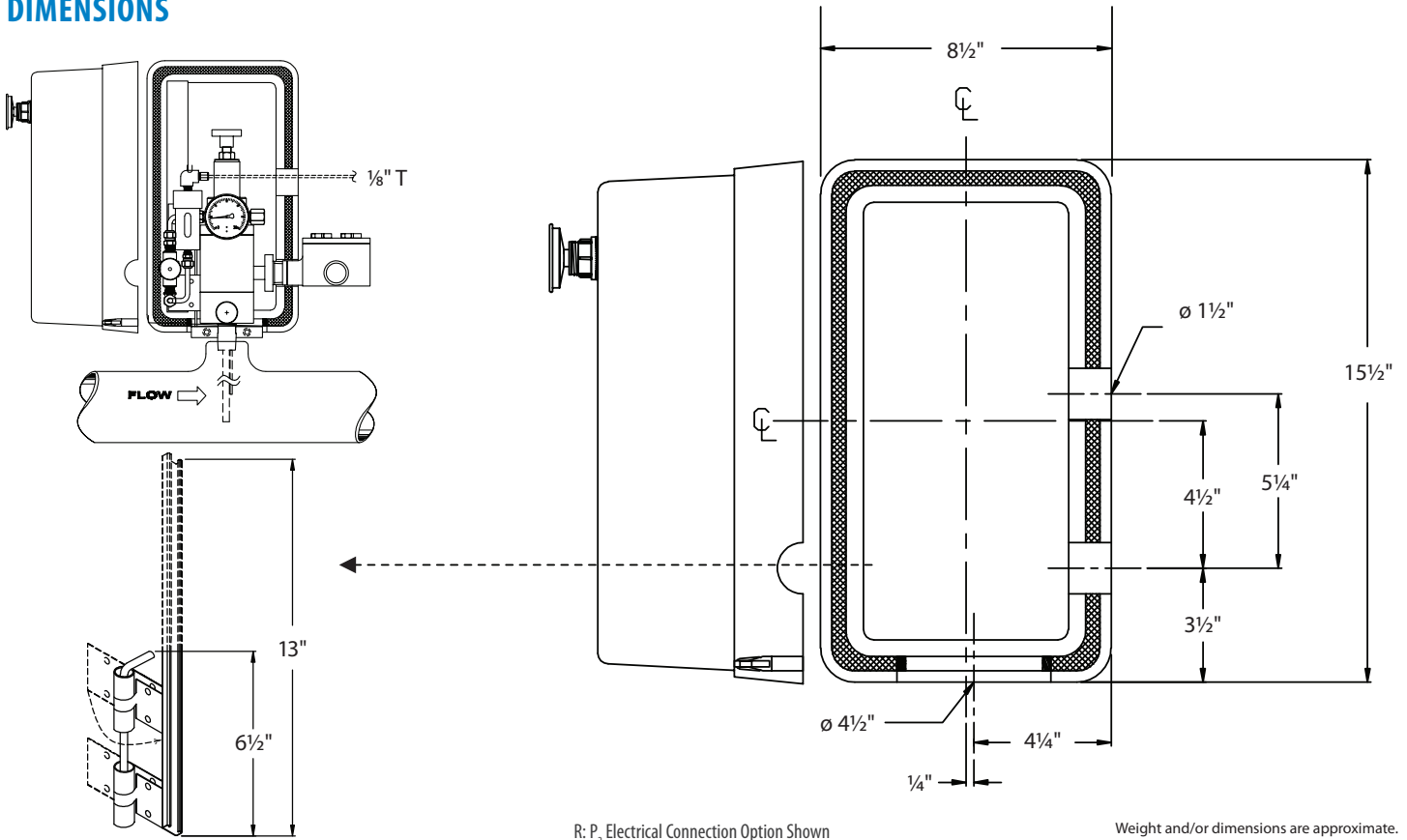

Weight and/or dimensions are approximate. Specifications subject to change without notice.

